

BALT[®]

KAT-11 Laser and Dot Matrix Printer Stand

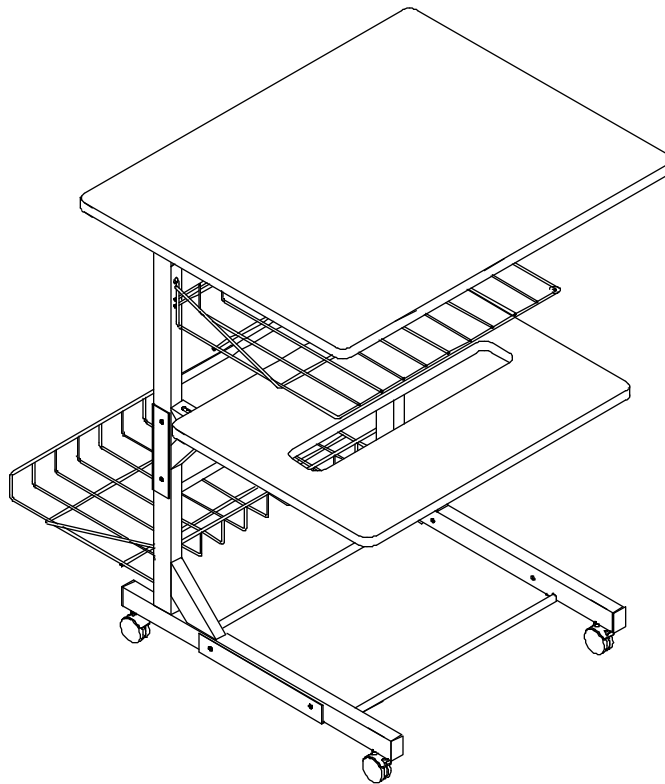











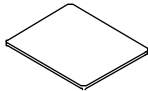

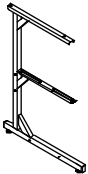

Assembly Instructions

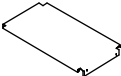
See back for important information, including our
Toll-Free Customer Service Telephone Number

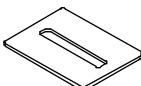
KAT-11 Laser and Dot Matrix Printer Stand

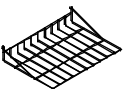
Parts List

Hardware List

Part	Drawing	Description	Qty	Drawing	Description	Qty
P-1		Top Panel	1 EA		Leveling Feet	4 EA
P-2		Leg Assembly	2 EA		#10-32 x 1/2" Socket Screw	16 EA
P-3		Back Stability Panel	1 EA		Interior Threaded Post	8 EA
P-4		Bottom Stability Panel	1 EA		2" Locking Casters(for front)	2 EA
P-5		Bottom Printer Platform	1 EA		2" Casters(for Back)	2 EA
P-6		Input Paper Basket	1 EA		Allen Wrench	1 EA
P-7		Refold Forms Basket	1 EA		Cable Clips	4 EA

To Assemble: *(For convenience Printer Platforms may be installed with unit turned up-side-down.)*

- 1.) Attach Bottom Stability Panel #P-4 to the (2) each Leg Assemblies #P-2 using (4) each #10-32 x 1/2" Socket Screws and Internal Threaded Posts.
- 2.) Attach Back Stability Panel #P-3 to the (2) each Leg Assemblies #P-2 using (4) each #10-32 x 1/2" Socket Screws and Internal Threaded Posts.
- 3.) Attach Top Printer Platform #P-1 to the (2) each Leg Assemblies #P-2 using (4) each #10-32 x 1/2" Socket Screws.
- 4.) Attach Bottom Printer Platform #P-5 to the (2) each Leg Assemblies #P-2 using (4) each #10-32 x 1/2" Socket Screws.
- 5.) Attach Leveling Feet or Casters to Leg Assembly #P-2.
- 6.) Attach the Input Paper Basket #P6 and Refold Forms Basket #P-7 to (2) each Leg Assemblies #P-2.

Important Information:

Do not use unless all screws are tight.
 At least every six months, check all screws to be sure they are tight.
 If parts are missing, broken, damaged, or worn, stop use of the product until repairs are made by your dealer using factory authorized parts.

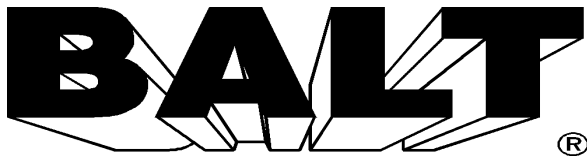

KAT-11 Laser and Dot Matrix Printer Stand Assembly Diagram

2.) Attach Back Stability Panel #P-3 to the (2) each Leg Assemblies #P-2.

3.) Attach Top Printer Platform #P-1 to the (2) each Leg Assemblies #P-2.

4.) Attach Bottom Printer Platform #P-5 to the (2) each Leg Assemblies #P-2.

6.) Attach the Input Paper Basket #P6 and Refold Forms Basket #P-7 to the (2) each Leg Assemblies #P-2.

1.) Attach Bottom Stability Panel #P-4 to the (2) each Leg Assemblies #P-2.

5.) Attach Leveling Feet or Casters to (2) each Leg Assemblies #P-2.

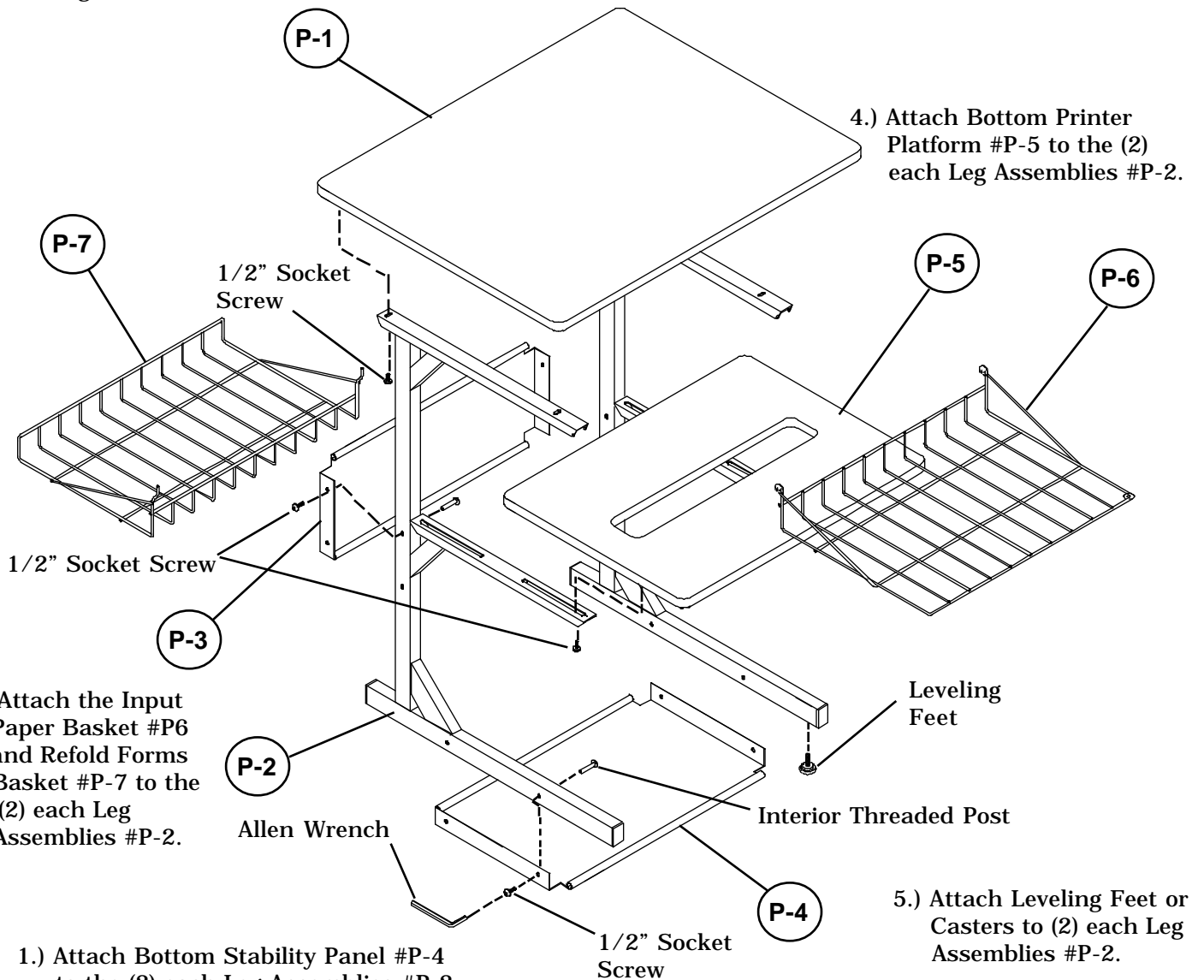

Note: It is recommended that when attaching stability panels, loosely tighten until all four screws and interior threaded posts are positioned before fully tightening with Allen Wrench.

Important

The Balt product you have purchased is guaranteed against material and workmanship defects. This guarantee extends 1 year from date of purchase.

Should this product fail to function satisfactorily under normal use due to defect or imperfection, the defective part or product will be replaced. Damage caused by common carriers during shipment is not included in this guarantee.

This guarantee sets forth all applicable guarantees and remedies. No other warranty, expressed or implied shall apply. Failure to follow instructions found in Important Information Section of Owner Sheet shall void the guarantee. Consequential or incidental damages and or costs are not refundable.

Toll-Free Customer Service

1-800-749-2258

*Should you require assistance during assembly,
please call our Customer Service Department
Monday - Friday 8 a.m. - 5 p.m.
Central Standard Time*